

SVENSK STANDARD

SS-EN 10264-3:2012

Fastställt/Approved: 2012-01-20
Publicerad/Published: 2012-01-26
Utgåva/Edition: 2
Språk/Language: engelska/English
ICS: 21.220.20; 77.140.65

Tråd och trådprodukter av stål – Tråd av stål för linor – Del 3: Rund och formad olegerad tråd för linor för krävande ändamål

Steel wire and wire products – Steel wire for ropes – Part 3: Round and shaped non alloyed steel wire for high duty applications

This preview is downloaded from www.sis.se. Buy the entire standard via <https://www.sis.se/std-84833>

Standarder får världen att fungera

SIS (Swedish Standards Institute) är en fristående ideell förening med medlemmar från både privat och offentlig sektor. Vi är en del av det europeiska och globala nätverk som utarbetar internationella standarder. Standarder är dokumenterad kunskap utvecklad av framstående aktörer inom industri, näringsliv och samhälle och befrämjar handel över gränser, bidrar till att processer och produkter blir säkrare samt effektiviserar din verksamhet.

Delta och påverka

Som medlem i SIS har du möjlighet att påverka framtida standarder inom ditt område på nationell, europeisk och global nivå. Du får samtidigt tillgång till tidig information om utvecklingen inom din bransch.

Ta del av det färdiga arbetet

Vi erbjuder våra kunder allt som rör standarder och deras tillämpning. Hos oss kan du köpa alla publikationer du behöver – allt från enskilda standarder, tekniska rapporter och standardpaket till handböcker och onlinetjänster. Genom vår webbtjänst e-nav får du tillgång till ett lättnavigerat bibliotek där alla standarder som är aktuella för ditt företag finns tillgängliga. Standarder och handböcker är källor till kunskap. Vi säljer dem.

Utveckla din kompetens och lyckas bättre i ditt arbete

Hos SIS kan du gå öppna eller företagsinterna utbildningar kring innehåll och tillämpning av standarder. Genom vår närhet till den internationella utvecklingen och ISO får du rätt kunskap i rätt tid, direkt från källan. Med vår kunskap om standarders möjligheter hjälper vi våra kunder att skapa verklig nytta och lönsamhet i sina verksamheter.

Vill du veta mer om SIS eller hur standarder kan effektivisera din verksamhet är du välkommen in på www.sis.se eller ta kontakt med oss på tel 08-555 523 00.



Standards make the world go round

SIS (Swedish Standards Institute) is an independent non-profit organisation with members from both the private and public sectors. We are part of the European and global network that draws up international standards. Standards consist of documented knowledge developed by prominent actors within the industry, business world and society. They promote cross-border trade, they help to make processes and products safer and they streamline your organisation.

Take part and have influence

As a member of SIS you will have the possibility to participate in standardization activities on national, European and global level. The membership in SIS will give you the opportunity to influence future standards and gain access to early stage information about developments within your field.

Get to know the finished work

We offer our customers everything in connection with standards and their application. You can purchase all the publications you need from us - everything from individual standards, technical reports and standard packages through to manuals and online services. Our web service e-nav gives you access to an easy-to-navigate library where all standards that are relevant to your company are available. Standards and manuals are sources of knowledge. We sell them.

Increase understanding and improve perception

With SIS you can undergo either shared or in-house training in the content and application of standards. Thanks to our proximity to international development and ISO you receive the right knowledge at the right time, direct from the source. With our knowledge about the potential of standards, we assist our customers in creating tangible benefit and profitability in their organisations.

If you want to know more about SIS, or how standards can streamline your organisation, please visit www.sis.se or contact us on phone +46 (0)8-555 523 00



Europastandarden EN 10264-3:2012 gäller som svensk standard. Detta dokument innehåller den officiella engelska versionen av EN 10264-3:2012.

Denna standard ersätter SS-EN 10264-3, utgåva 1.

The European Standard EN 10264-3:2012 has the status of a Swedish Standard. This document contains the official version of EN 10264-3:2012.

This standard supersedes the Swedish Standard SS-EN 10264-3, edition 1.

© Copyright/Upphovsrätten till denna produkt tillhör SIS, Swedish Standards Institute, Stockholm, Sverige. Användningen av denna produkt regleras av slutanvändarlicensen som återfinns i denna produkt, se standardens sista sidor.

© Copyright SIS, Swedish Standards Institute, Stockholm, Sweden. All rights reserved. The use of this product is governed by the end-user licence for this product. You will find the licence in the end of this document.

Uppllysningar om sakinnehållet i standarden lämnas av SIS, Swedish Standards Institute, telefon 08-555 520 00. Standarder kan beställas hos SIS Förlag AB som även lämnar allmänna uppllysningar om svensk och utländsk standard.

Information about the content of the standard is available from the Swedish Standards Institute (SIS), telephone +46 8 555 520 00. Standards may be ordered from SIS Förlag AB, who can also provide general information about Swedish and foreign standards.

Denna standard är framtagen av kommittén för Tråd och trådprodukter, SIS/TK 138.

Har du synpunkter på innehållet i den här standarden, vill du delta i ett kommande revideringsarbete eller vara med och ta fram andra standarder inom området? Gå in på www.sis.se - där hittar du mer information.

EUROPEAN STANDARD

EN 10264-3

NORME EUROPÉENNE

EUROPÄISCHE NORM

January 2012

ICS 77.140.65

Supersedes EN 10264-3:2002

English Version

**Steel wire and wire products - Steel wire for ropes - Part 3:
Round and shaped non alloyed steel wire for high duty
applications**

Fils et produits tréfilés en acier - Fils pour câbles - Partie 3:
Fils ronds et profilés, en acier non aillé, pour fortes
sollicitations

Stahldraht und Drahterzeugnisse - Stahldraht für Seile -
Teil 3: Runder und profilierter Draht aus unlegiertem Stahl
für hohe Beanspruchungen

This European Standard was approved by CEN on 19 November 2011.

CEN members are bound to comply with the CEN/CENELEC Internal Regulations which stipulate the conditions for giving this European Standard the status of a national standard without any alteration. Up-to-date lists and bibliographical references concerning such national standards may be obtained on application to the CEN-CENELEC Management Centre or to any CEN member.

This European Standard exists in three official versions (English, French, German). A version in any other language made by translation under the responsibility of a CEN member into its own language and notified to the CEN-CENELEC Management Centre has the same status as the official versions.

CEN members are the national standards bodies of Austria, Belgium, Bulgaria, Croatia, Cyprus, Czech Republic, Denmark, Estonia, Finland, France, Germany, Greece, Hungary, Iceland, Ireland, Italy, Latvia, Lithuania, Luxembourg, Malta, Netherlands, Norway, Poland, Portugal, Romania, Slovakia, Slovenia, Spain, Sweden, Switzerland, Turkey and United Kingdom.



EUROPEAN COMMITTEE FOR STANDARDIZATION
COMITÉ EUROPÉEN DE NORMALISATION
EUROPÄISCHES KOMITEE FÜR NORMUNG

Management Centre: Avenue Marnix 17, B-1000 Brussels

Contents		Page
Foreword.....		3
1	Scope	4
2	Normative references	4
3	Designation of the product	5
4	General conditions of manufacture	5
5	Characteristics of the wire	5
5.1	Tensile strength grades	5
5.2	Profiles	6
5.2.1	Definition of shaped wire	6
5.2.2	Equivalent diameter	8
5.3	Minimum requirements for wire characteristics.....	8
5.3.1	Dimension – measured values	8
5.3.2	Reverse bend test	9
5.3.3	Torsion test	12
5.3.4	Zinc and Zn95/Al5 coatings	14
6	Test methods.....	15
6.1	General.....	15
6.2	Reverse bend test	15

Foreword

This document (EN 10264-3:2012) has been prepared by Technical Committee ECISS/TC 106 "Wire rod and wires", the secretariat of which is held by AFNOR.

This European Standard shall be given the status of a national standard, either by publication of an identical text or by endorsement, at the latest by July 2012, and conflicting national standards shall be withdrawn at the latest by July 2012.

Attention is drawn to the possibility that some of the elements of this document may be the subject of patent rights. CEN [and/or CENELEC] shall not be held responsible for identifying any or all such patent rights.

This document supersedes EN 10264-3:2002.

This European Standard for wire for ropes is made up of the following parts:

- *Part 1: General requirements*
- *Part 2: Cold drawn non alloy steel wire for ropes for general applications*
- *Part 3: Round and shaped non alloyed steel wire for high duty applications*
- *Part 4: Stainless steel wire*

This European Standard has been technically revised to incorporate the following changes:

- a) heavy duty applications have been explained in the new last sentence of the scope;
- b) the purity of the zinc coating of the drawn wire has been specified according the relevant EN 1179 (see Clause 4);
- c) a footnote c) has been added in Table 1 in order to precise the meaning of coated;
- d) the values of the Z and H profiles have been updated in Table 2;
- e) a note has been added to allow other wire diameters higher than those given in Table 3 "Dimensional tolerances on round wire diameter" subject to an agreement between supplier and user at the time of order;
- f) modifications have been made on values concerning "Coated – Class A" given in Table 4 "Dimensional tolerances for shaped wire";
- g) modifications have been made in Table 5 "Minimum number of reverse bends for shaped wire for static applications" concerning the values of Z profile for the height of profile upper to 5 mm;
- h) a second quality of zinc coating has been added for dynamic applications (see 5.3.4);
- i) three additional ranges for Nominal dimensions of round wire (from 0,50 mm to 0,80 mm) have been added (see Table 11 "Minimum mass of coating").

According to the CEN/CENELEC Internal Regulations, the national standards organizations of the following countries are bound to implement this European Standard: Austria, Belgium, Bulgaria, Croatia, Cyprus, Czech Republic, Denmark, Estonia, Finland, France, Germany, Greece, Hungary, Iceland, Ireland, Italy, Latvia, Lithuania, Luxembourg, Malta, Netherlands, Norway, Poland, Portugal, Romania, Slovakia, Slovenia, Spain, Sweden, Switzerland, Turkey and the United Kingdom.

SS-EN 10264-3:2012 (E)

1 Scope

This part of this European Standard specifies round and shaped non alloyed steel wire for use in the manufacture of ropes for mine hoisting, man-riding haulage, cableways for the transportation of passengers and other high duty applications. Heavy duty refers to situations where the stresses applied to the rope are either high or vary by a large amount during service.

This part of this European Standard refers to round wires and three types of shaped wire: full lock (Z), half lock (H) and trapezoidal (T).

In addition to the requirements of this part of this European Standard, the requirements of EN 10264-1 also apply.

It does not apply to steel wire taken from manufactured ropes.

This part of this European Standard specifies the following for cold drawn non alloyed steel wire for ropes for high duty applications:

- dimensional tolerances;
- mechanical characteristics;
- requirements relating to the chemical composition of the steel wire;
- conditions to be satisfied by any coating.

2 Normative references

The following referenced documents are indispensable for the application of this document. For dated references, only the edition cited applies. For undated references, the latest edition of the referenced document (including any amendments) applies.

EN 1179, *Zinc and zinc alloys — Primary zinc*

EN 10218-1, *Steel wire and wire products — General — Part 1: Test methods*

EN 10244-2, *Steel wire and wire products — Non-ferrous metallic coatings on steel wire — Part 2: Zinc or zinc alloy coatings*

EN 10264-1:2011, *Steel wire and wire products — Steel wire for ropes — Part 1: General requirements*

EN ISO 16120-1:2011, *Non-alloy steel wire rod for conversion to wire - Part 1: General requirements (ISO 16120-1:2011)*

EN ISO 16120-2:2011, *Non-alloy steel wire rod for conversion to wire - Part 2: Specific requirements for general-purpose wire rod (ISO 16120-2:2011)*

EN ISO 16120-4:2011, *Non-alloy steel wire rod for conversion to wire - Part 4: Specific requirements for wire rod for special applications (ISO 16120-4:2011)*

3 Designation of the product

The designation of wire for ropes manufactured in accordance with this European Standard shall be based on the nominal dimension, surface appearance and tensile strength.

The indicator of dimension for round wire is the nominal diameter; for shaped wire it is the value of the height (h), followed by a letter specifying the profile. In the case of H profiles, this indicator shall be followed by the value of the narrowing.

The surface appearance shall be indicated as defined in EN 10264-1 with U for uncoated or bright wire, with a letter indicating the class of coating (A, B, ...) and in the case of zinc alloy coatings, indicating in brackets (Zn/Al).

EXAMPLE 1 2,0 mm wire for rope with thick zinc layer, class A, tensile strength grade 1 570 MPa, in accordance with EN 10264-3.

Designation: wire for rope EN 10264-3 – 2,0 - A – 1 570

EXAMPLE 2 Wire for rope, trapezoidal profile, $h = 3,5$ mm, class B zinc coated, tensile strength grade 1 770 MPa, in accordance with EN 10264-3.

Designation: wire for rope EN 10264-3 - T3,5 - B – 1 770

EXAMPLE 3 H shaped wire for rope $h = 3,0$ mm, $w = 1,8$ mm, coated with class A zinc alloy, tensile strength grade 1 370 MPa, in accordance with EN 10264-3.

Designation: wire for rope EN 10264-3 - H – 3,0 × 1,8 - A (Zn/Al) – 1 370

4 General conditions of manufacture

The drawn wire shall be manufactured from rod in accordance with EN ISO 16120-1 and EN ISO 16120-2 for ropes for static applications, and in accordance with EN ISO 16120-1 and EN ISO 16120-4 for ropes for dynamic applications.

The drawn wire shall show no surface defects or internal defects prejudicial to its use.

When specified, the drawn wire shall be supplied with a coating applied by a hot dipping or electrolytic method. The coatings commonly used are zinc or Zn95/Al5.

Unless otherwise specified, the zinc used for coating shall have a purity of 99,95 % according to EN 1179, Z3, other zinc alloys may be agreed at the time of enquiry and order.

NOTE If required by the purchaser, the quality of the zinc or zinc alloy used for the coating material (zinc or zinc alloy) should be certified by the manufacturer. Because of the reaction between the base material and coating material, which is inherent to the process, the composition of the coating on the wire is different to that used in the coating bath.

5 Characteristics of the wire

5.1 Tensile strength grades

The tensile strength grades are defined in Table 1.

NOTE The nominal values are the minimum tensile strength limits. The upper limits (maximum) are equal to these minimum values increased with the tolerances specified in EN 10264-1:2011, Table 1.

Table 1 — Tensile strength grade

Quality of wire ^c		Nominal tensile strength grade							
		MPa ^a							
Round	Bright or coated Class B	—	—	—	1 570	—	1 770	1 960	2 160
	Zinc or Zn95/Al5 - Class A	—	—	—	1 570	—	1 770	—	—
Shaped	Bright or coated Class B or class D ^b	—	1 370	—	1 570	—	1 770	—	—
		1 270	1 370	1 470	1 570	1 670	1 770	—	—
	Zinc or Zn95/Al5 - Class A	—	1 370	—	1 570	—	—	—	—
NOTE Subject to agreement between the manufacturer and the purchaser, other tensile strength grades can be used.									
^a 1 MPa = 1 N/mm ² .									
^b Mass of coatings for static and dynamic applications are specified in Table 11.									
^c Coated means zinc or Zn95/Al5 alloy.									

5.2 Profiles

5.2.1 Definition of shaped wire

For shaped wire, the characteristic sections of the wire are shown in Figure 1 for full lock Z, half lock H and trapezoidal T wires.

The nominal dimensions and tolerances shall be agreed between the supplier and the purchaser at the time of ordering. The conventional characteristic values are as follows:

h height: difference between the radii of the 2 concentric boundary circles;

b width: maximum width of upper part perpendicular to a radial line passing through the centre of the width (as shown in Figure 1);

w minimum narrowing: smallest width of the profile;

e distance taken diagonally across the transverse section of the profile (essentially T or Z profiles).

The designation of a full lock wire is established using the letter Z and the height (*h*), that of a half lock wire by H followed by the height (*h*) and the minimum narrowing (*w*) (*h* × *w*) and that of a trapezoidal wire by the letter T followed by the height (*h*).

Table 2 gives the design criteria for the shaped wire shown in Figure 1. These are the relation between the height of the shaped wires and the other major characteristic dimensions.

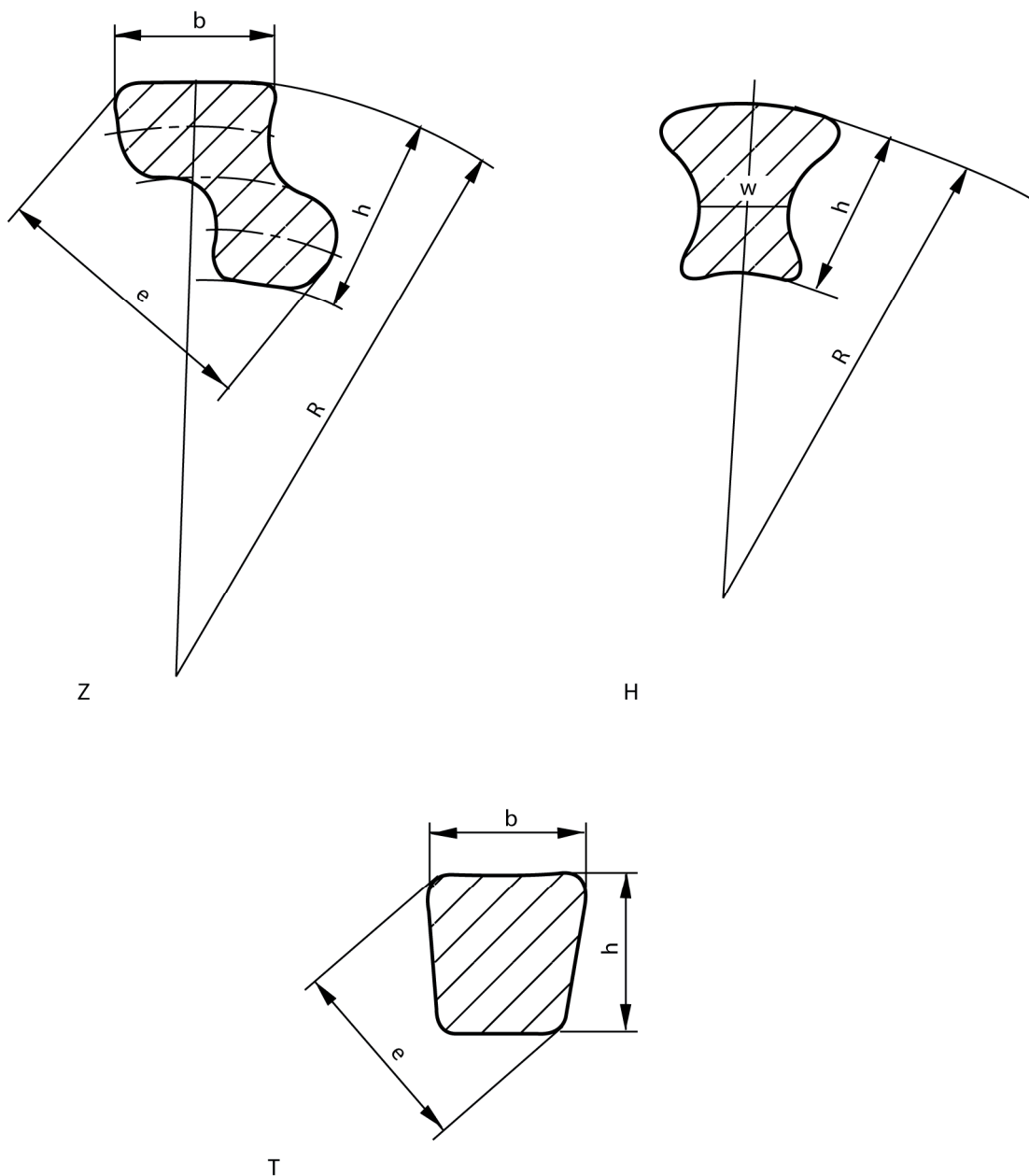

Figure 1 — Shaped wire sections

Table 2 — Design criteria for shaped wire

Ratio	Z profile	H profile	Trapezoidal profile T
$h : b$	0,9 to 1,55	-	1,0 to 1,3
$h : e$	0,55 to 0,80	-	0,75 to 0,90
$h : w$	-	0,8 to 2,3	