

SVENSK STANDARD

SS-ISO 21058:2020

Vägfordon – Koppling för påfyllning av dimetyleter (DME)  
(ISO 21058:2019, IDT)

Road vehicles – Dimethyl Ether (DME) refuelling connector  
(ISO 21058:2019, IDT)



**sis** Svenska  
Institutet för  
Standarder

Language: engelska/English

Edition: 1

This preview is downloaded from [www.sis.se](http://www.sis.se). Buy the entire standard via <https://www.sis.se/std-80019308>

Den här standarden kan hjälpa dig att effektivisera och kvalitetssäkra ditt arbete. SIS har fler tjänster att erbjuda dig för att underlätta tillämpningen av standarder i din verksamhet.

#### **SIS Abonnemang**

Snabb och enkel åtkomst till gällande standard med SIS Abonnemang, en prenumerationstjänst genom vilken din organisation får tillgång till all världens standarder, senaste uppdateringarna och där hela din organisation kan ta del av innehållet i prenumerationen.

#### **Utbildning, event och publikationer**

Vi erbjuder även utbildningar, rådgivning och event kring våra mest sålda standarder och frågor kopplade till utveckling av standarder. Vi ger också ut handböcker som underlättar ditt arbete med att använda en specifik standard.

#### **Vill du delta i ett standardiseringsprojekt?**

Genom att delta som expert i någon av SIS 300 tekniska kommittéer inom CEN (europeisk standardisering) och/eller ISO (internationell standardisering) har du möjlighet att påverka standardiseringsarbetet i frågor som är viktiga för din organisation. Välkommen att kontakta SIS för att få veta mer!

#### **Kontakt**

Skriv till [kundservice@sis.se](mailto:kundservice@sis.se), besök [sis.se](https://www.sis.se) eller ring 08 - 555 523 10

---

© Copyright/Upphovsrätten till denna produkt tillhör Svenska institutet för standarder, Stockholm, Sverige. Upphovsrätten och användningen av denna produkt regleras i slutanvändarlicensen som återfinns på [sis.se/slutanvandarlicens](https://www.sis.se/slutanvandarlicens) och som du automatiskt blir bunden av när du använder produkten. För ordlista och förkortningar se [sis.se/ordlista](https://www.sis.se/ordlista).

© Copyright Svenska institutet för standarder, Stockholm, Sweden. All rights reserved. The copyright and use of this product is governed by the end-user licence agreement which you automatically will be bound to when using the product. You will find the licence at [sis.se/enduserlicenseagreement](https://www.sis.se/enduserlicenseagreement).

Upplysningar om sakinnehållet i standarden lämnas av Svenska institutet för standarder, telefon 08 - 555 520 00. Standarder kan beställas hos SIS som även lämnar allmänna upplysningar om svensk och utländsk standard.

Standarden är framtagen av kommittén för Motorer i bilar, SIS/TK 220.

Har du synpunkter på innehållet i den här standarden, vill du delta i ett kommande revideringsarbete eller vara med och ta fram andra standarder inom området? Gå in på [www.sis.se](https://www.sis.se) - där hittar du mer information.

Den internationella standarden ISO 21058:2019 gäller som svensk standard. Detta dokument innehåller den officiella engelska versionen av ISO 21058:2019.

The International Standard ISO 21058:2019 has the status of a Swedish Standard. This document contains the official English version of ISO 21058:2019.

# Contents

Page

<b>Foreword</b> .....	<b>v</b>
<b>Introduction</b> .....	<b>vi</b>
<b>1 Scope</b> .....	<b>7</b>
<b>2 Normative References</b> .....	<b>7</b>
<b>3 Terms and definitions</b> .....	<b>7</b>
<b>4 General construction requirements</b> .....	<b>8</b>
<b>5 Nozzles</b> .....	<b>9</b>
<b>6 Standard receptacle dimensions</b> .....	<b>10</b>
<b>7 Receptacles</b> .....	<b>11</b>
<b>8 Instructions</b> .....	<b>12</b>
<b>9 Marking</b> .....	<b>12</b>
<b>10 Tests</b> .....	<b>13</b>
10.1 General requirements .....	13
10.2 Impact resistance.....	13
10.2.1 Nozzle test.....	13
10.2.2 Receptacle test.....	13
10.3 Leakage at room temperature.....	14
10.4 Abnormal loads .....	14
10.4.1 Test in unpressurised condition .....	15
10.4.2 Test in pressurised condition.....	15
10.5 Mounting hardware torque .....	16
10.6 Leakage at low and high temperatures .....	16
10.7 Nozzle freezing .....	16
10.8 Durability .....	16
10.8.1 Endurance .....	16
10.8.2 Corrosion resistance.....	18
10.8.3 Brass material compatibility.....	19
10.8.4 Resistance to dry heat.....	19
10.8.5 Ozone ageing.....	19
10.8.6 Temperature cycle .....	20
10.8.7 Compatibility to Dimethyl Ether.....	20
10.8.8 Electrical continuity.....	20
10.9 Hydrostatic strength.....	20
10.10 Oxygen ageing .....	21
10.11 Non-metallic material immersion .....	21
10.12 Vibration resistance.....	22
10.13 Creep .....	22
10.14 Automotive fluid exposure .....	22
10.14.1 General.....	22
10.14.2 Test method.....	22
10.14.3 Fluids.....	23
10.14.4 Pass criteria .....	23
<b>Annex A (normative) Critical dimensions of the nozzle</b> .....	<b>24</b>
<b>Annex B (informative) Manufacturing and production test plan</b> .....	<b>25</b>
<b>Bibliography</b> .....	<b>26</b>

## Foreword

ISO (the International Organization for Standardization) is a worldwide federation of national standards bodies (ISO member bodies). The work of preparing International Standards is normally carried out through ISO technical committees. Each member body interested in a subject for which a technical committee has been established has the right to be represented on that committee. International organizations, governmental and non-governmental, in liaison with ISO, also take part in the work. ISO collaborates closely with the International Electrotechnical Commission (IEC) on all matters of electrotechnical standardization.

The procedures used to develop this document and those intended for its further maintenance are described in the ISO/IEC Directives, Part 1. In particular, the different approval criteria needed for the different types of ISO documents should be noted. This document was drafted in accordance with the editorial rules of the ISO/IEC Directives, Part 2 (see [www.iso.org/directives](http://www.iso.org/directives)).

Attention is drawn to the possibility that some of the elements of this document may be the subject of patent rights. ISO shall not be held responsible for identifying any or all such patent rights. Details of any patent rights identified during the development of the document will be in the Introduction and/or on the ISO list of patent declarations received (see [www.iso.org/patents](http://www.iso.org/patents)).

Any trade name used in this document is information given for the convenience of users and does not constitute an endorsement.

For an explanation of the voluntary nature of standards, the meaning of ISO specific terms and expressions related to conformity assessment, as well as information about ISO's adherence to the World Trade Organization (WTO) principles in the Technical Barriers to Trade (TBT) see [www.iso.org/iso/foreword.html](http://www.iso.org/iso/foreword.html).

This document was prepared by Technical Committee ISO/TC 22, *Road vehicles*, Subcommittee SC 41, *Specific aspects for gaseous fuels*.

Any feedback or questions on this document should be directed to the user's national standards body. A complete listing of these bodies can be found at [www.iso.org/members.html](http://www.iso.org/members.html).

## Introduction

This document was developed to use for the newly produced Dimethyl Ether vehicle fuelling nozzles and receptacles only. As such, it applies to nozzles and receptacles used in the Dimethyl Ether fuelling system and not to the system.

A nozzle meeting the requirements of this document will be functionally compatible from a safety and performance perspective with all listed receptacles of compatible profile and system pressure. Similarly, a receptacle meeting the requirements of this document will be functionally compatible from a safety and performance perspective with all listed nozzles of compatible profile and system pressure.

As there may eventually be many different kinds of nozzles and receptacles available from a variety of manufacturers which, for safety reasons, should all be compatible with each other, this document specifies one standardized receptacle profile. This standard profile incorporates the design specifications (mating materials, geometry and tolerances) which may be considered when evaluating if a submitted nozzle or receptacle meets the requirement of this document.

# Road vehicles — Dimethyl Ether (DME) refuelling connector

## 1 Scope

This document applies only to Dimethyl Ether refuelling connectors hereinafter referred to as devices, constructed entirely of new, unused parts and materials. Dimethyl Ether refuelling connectors consist of the following components, as applicable:

- a) Nozzle (mounted on dispenser side).
- b) Receptacle (mounted on vehicle).

This document applies to devices which use Dimethyl Ether as fuel, hereinafter referred to in this document as D15 [see 9.1 c)].

This document applies to devices with standardised mating components.

This document applies to connectors which prevent Dimethyl Ether vehicles from being fuelled by fuel station dispensers for other gaseous fuels.

This document is applicable to: Dimethyl Ether in accordance with ISO 16861.

NOTE All references to pressures (kPa) throughout this document are considered gauge pressures unless otherwise specified.

## 2 Normative References

The following documents are referred to in the text in such a way that some or all of their content constitutes requirements of this document. For dated references, only the edition cited applies. For undated references, the latest edition of the referenced document (including any amendments) applies.

ISO 188, *Rubber, vulcanized or thermoplastic — Accelerated ageing and heat resistance tests*

ISO 1431-1, *Rubber, vulcanized or thermoplastic — Resistance to ozone cracking — Part 1: Static and dynamic strain testing*

ISO 1817, *Rubber, vulcanized or thermoplastic — Determination of the effect of liquids*

ISO 9227, *Corrosion tests in artificial atmospheres — Salt spray tests*

ISO 16861, *Petroleum products — Fuels (class F) — Specifications of dimethyl ether (DME)*

ASTM D4814 *Standard Specification for Automotive Spark-Ignition Engine Fuel*

## 3 Terms and definitions

For the purposes of this document, the following terms and definitions apply.

ISO and IEC maintain terminological databases for use in standardization at the following addresses:

- ISO Online browsing platform: available at <https://www.iso.org/obp>
- IEC Electropedia: available at <http://www.electropedia.org/>

### 3.1

#### dry air

air with moisture content such that the dew point of the air at the required test pressure is at least 11 °C below the ambient test temperature

## SS-ISO 21058:2020 (E)

### 3.2 working pressure

maximum pressure that a connector can be expected to withstand in actual service

### 3.3 Dimethyl Ether DME

methoxymethane  
organic compound with the formula  $\text{CH}_3\text{OCH}_3$ , simplified to  $\text{C}_2\text{H}_6\text{O}$

Note 1 to entry: Dimethyl Ether is liquid below  $-25^\circ\text{C}$ .

### 3.4 Dimethyl Ether refuelling nozzle

device which permits quick connection and disconnection of fuel supply hose to the *Dimethyl Ether receptacle* (3.5) in a safe manner

Note 1 to entry: This term is hereafter referred to as nozzle.

### 3.5 Dimethyl Ether refuelling receptacle

device connected to a vehicle or storage system which receives the *Dimethyl Ether nozzle* (3.4) and permits safe transfer of fuel

Note 1 to entry: This term is hereafter referred to as receptacle.

### 3.6 Dimethyl Ether refuelling connector

joined assembly of Dimethyl Ether nozzle and receptacle

Note 1 to entry: This term is hereafter referred to as connector.

### 3.7 non-sparking materials

materials that do not contain, by mass, more than 7,5 % in total of magnesium, titanium and zirconium

[SOURCE: IEC EN 60079-0:2011, 8.3]

### 3.8 service gasket

replaceable gasket ensuring tightness of the connection between the nozzle outlet and the receptacle inlet

### 3.9 cycle life

number of connections and disconnections between the *nozzle* (3.4) and the *receptacle* (3.5) required for testing purposes

### 3.10 service life

number of operations of the check valve in the receptacle for testing purposes

## 4 General construction requirements

4.1 Nozzles and receptacles shall be designed in accordance with reasonable concepts of safety, durability and maintainability.

- 1) Working pressure. All nozzles and receptacles are designed to have a working pressure defined by the manufacturer and clearly marked on the device [see 9.1 d)].



2) Design life. All nozzles will be tested at 100 000 connect/disconnect cycles and all receptacles at 20 000 connect/disconnect cycles for conformity with this document. The service gasket may be changed after minimum of 20 000 cycles.

**4.2** Nozzles and receptacles shall be well fitted and manufactured in accordance with good engineering practice. All construction requirements may be met by either the construction specified in this document or another construction that gives at least equivalent performance.

**4.3** Nozzles and receptacles shall be:

- designed to minimise the possibility of incorrect assembly;
- designed to be secure against displacement, distortion, warping or other damage under normal and anticipated abnormal conditions of handling and use;
- designed to release less than 1 cm<sup>3</sup> of liquid DME during disconnection;
- constructed to maintain operational integrity under normal and reasonable conditions of handling and usage;
- manufactured and produced according to the test plan in [Annex B](#).

**4.4** Nozzles and receptacles shall be manufactured of materials suitable and compatible for use with Dimethyl Ether, in accordance with ISO 16861, at the pressure and the temperature ranges to which it will be subjected.

**4.4.1** The temperature range shall be for:

For the receptacle:

- Moderate operating conditions: -20 °C to +85 °C
- Cold operating conditions: -40 °C to +85 °C

For the nozzle:

- Moderate operating conditions: -20 °C to +65 °C
- Cold operating conditions: -40 °C to +65 °C

For specific regions, the temperature range specified may not be sufficient. In such a case, a wider temperature range, representative of that specific region, shall be considered.

**4.5** Nozzles and receptacles shall be operated either to connect or disconnect without the use of tools and with one hand operation.

**4.6** Jointing components shall provide gas-tight sealing performance.

## 5 Nozzles

The design of the nozzle shall ensure that:

- a) it is compatible with the receptacle as specified in [Clause 6](#);
- b) entrapment of fingers and/or cold burns are not possible;
- c) the maximum push-on force during connection is 100 N at any pressure up to 1 500 kPa in the nozzle;
- d) the maximum pull-off force during disconnection is 50 N at 1 500 kPa;

## SS-ISO 21058:2020 (E)

- e) the force to operate the lever, if any, applied at the centre of the grip area of the lever, is 100 N maximum at any pressure up to 1 500 kPa in the nozzle;
- f) if a latch is provided and in use, it shall be capable of being normally disarmed by the user;
- g) provision is made to enable the lever or the whole nozzle to freely rotate over an angle of 360° around the longitudinal axis of the nozzle or the filling hose;
- h) it is not possible to open the valve in the nozzle if the nozzle is not properly locked and sealed on the receptacle;
- i) a locking mechanism is incorporated that locks in the connected position;
- j) it is not possible to unlock the nozzle from the receptacle unless the nozzle valve is closed;
- k) internal blocking due to freezing does not occur under intended operating conditions;
- l) it will withstand a torque of 150 % of the mounting torque specified by the manufacturer without damage;
- m) the external surfaces of the filling nozzle are corrosion resistant or protected against corrosion and are made of materials (non-sparking materials) that do not cause sparks when dropped on a surface;
- n) changing the service gasket shall not result in any Dimethyl Ether release;
- o) the minimum cycle life of the service gasket is 20 000 cycles;
- p) the nozzle is provided with a means to securely attach it to the delivery hose;
- q) the nozzle shall comply with the performance requirements of [Clause 10](#) to ensure interchangeability.

## 6 Standard receptacle dimensions

A receptacle shall comply with the design specifications detailed in [Figure 1](#).

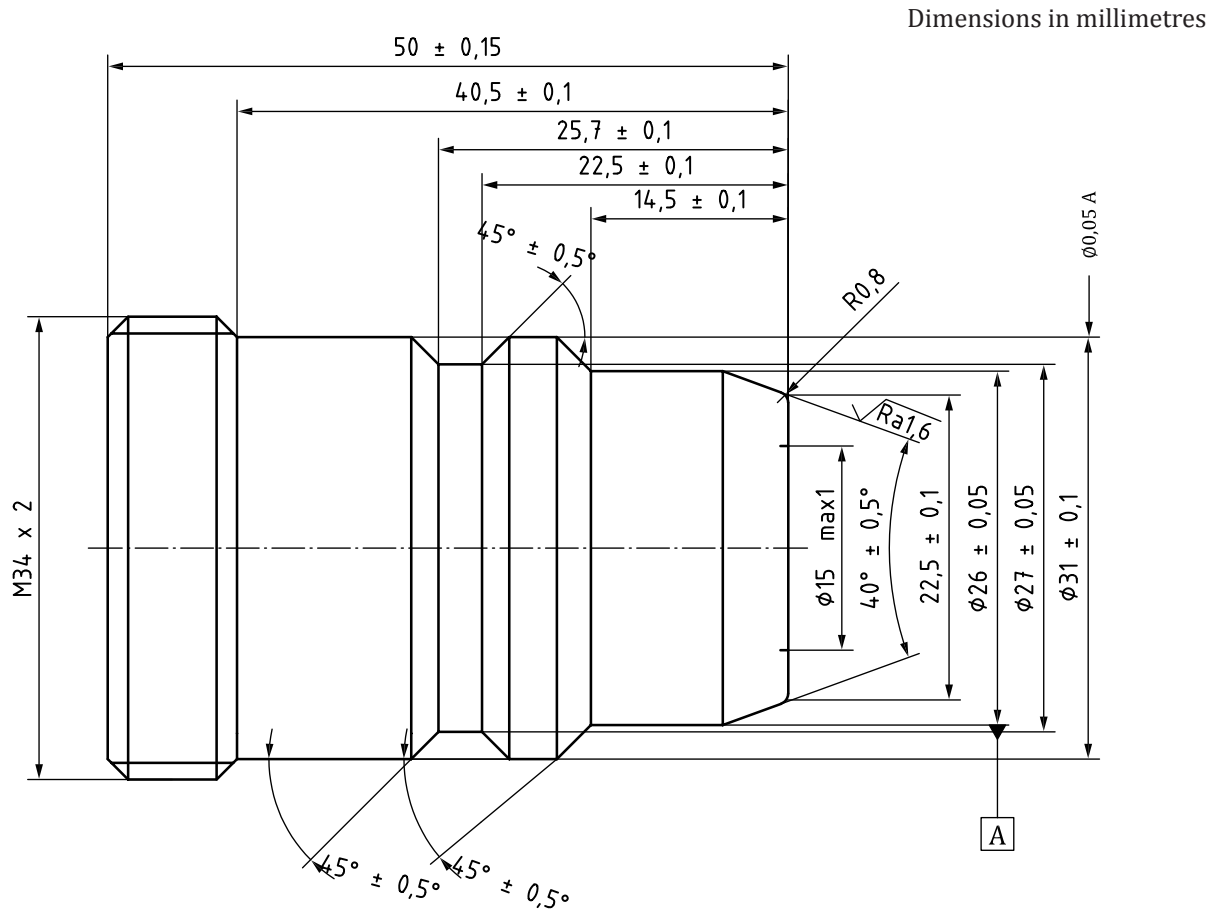

Figure 1 — D15 receptacle

## 7 Receptacles

7.1 Receptacles shall comply with [Clauses 4](#) and [6](#) to [10](#) and shall be evaluated with a test nozzle meeting the requirements of this document.

The failure of any test conducted with the receptacle and nozzle test samples shall constitute a failure of the submitted receptacle, unless the manufacturer can prove the problem was caused by the test nozzle.

7.2 The receptacle shall be equipped with an internal check valve to prevent the escape of gas. Regardless of whether the check valve is opened mechanically or by differential pressure, the flow through the receptacle, when tested with water, at a differential pressure of 30 kPa, shall be at least 3 l/min.

The check valve shall be dimensioned to be leak-tight for the complete temperature range, also when the tank pressure is lower than the ambient pressure.

The dead volume between the front sealing surface and the front of the internal check valve shall not exceed  $0,1 \text{ cm}^3$ .

7.3 The method for attaching the receptacle to the vehicle fuel system shall not rely on the joint between the male and female threads for sealing, such as conical threads.

7.4 The interfacing surface of the receptacle shall be constructed of material that does not cause spark (non-sparking) and ensures electrical continuity (see [10.8.8](#)).