



Handläggande organ

Fastställt

Utgåva

Sida

SVENSK MATERIAL- & MEKANSTANDARD, SMS

1999-04-30

1

1 (1+15)

© Copyright SIS. Reproduction in any form without permission is prohibited.

## Swap bodies – Thermal swap bodies of Class A – Dimensions and general requirements

The European Standard EN 12410:1999 has the status of a Swedish Standard. This document contains the official English version of EN 12410:1999.

Swedish Standards corresponding to documents referred to in this Standard are listed in "Catalogue of Swedish Standards", issued by SIS. The Catalogue lists, with reference number and year of Swedish approval, International and European Standards approved as Swedish Standards as well as other Swedish Standards.

## Växelflak med styrtunnel – Termiska växelflak – Klass A – Mått och allmänna krav

Europastandarden EN 12410:1999 gäller som svensk standard. Detta dokument innehåller den officiella engelska versionen av EN 12410:1999.

Motsvarigheten och aktualiteten i svensk standard till de publikationer som omnämns i denna standard framgår av "Katalog över svensk standard", som ges ut av SIS. I katalogen redovisas internationella och europeiska standarder som fastställts som svenska standarder och övriga gällande svenska standarder.

---

ICS 55.180.10

Standarder kan beställas hos SIS som även lämnar allmänna upplysningar om svensk och utländsk standard.  
Postadress: SIS, Box 6455, 113 82 STOCKHOLM  
Telefon: 08 - 610 30 00. Telefax: 08 - 30 77 57

Upplysningar om **sakinnehållet** i standarden lämnas av SMS.  
Telefon: 08 - 459 56 00. Telefax: 08 - 667 85 42  
E-post: [info@sms-standard.se](mailto:info@sms-standard.se)  
Prisgrupp P

Tryckt i juni 1999



EUROPEAN STANDARD

**EN 12410**

NORME EUROPÉENNE

EUROPÄISCHE NORM

April 1999

---

ICS 55.180.10

English version

## Swap bodies - Thermal swap bodies of Class A - Dimensions and general requirements

Caisses mobiles - Caisses mobiles à température dirigée  
de classe A - Dimensions et spécifications générales

Wechselbehälter - Thermal-Wechselbehälter der Klasse A -  
Maße und allgemeine Anforderungen

This European Standard was approved by CEN on 25 March 1999.

CEN members are bound to comply with the CEN/CENELEC Internal Regulations which stipulate the conditions for giving this European Standard the status of a national standard without any alteration. Up-to-date lists and bibliographical references concerning such national standards may be obtained on application to the Central Secretariat or to any CEN member.

This European Standard exists in three official versions (English, French, German). A version in any other language made by translation under the responsibility of a CEN member into its own language and notified to the Central Secretariat has the same status as the official versions.

CEN members are the national standards bodies of Austria, Belgium, Czech Republic, Denmark, Finland, France, Germany, Greece, Iceland, Ireland, Italy, Luxembourg, Netherlands, Norway, Portugal, Spain, Sweden, Switzerland and United Kingdom.



EUROPEAN COMMITTEE FOR STANDARDIZATION  
COMITÉ EUROPÉEN DE NORMALISATION  
EUROPÄISCHES KOMITEE FÜR NORMUNG

**Central Secretariat: rue de Stassart, 36 B-1050 Brussels**

---

## Contents

<b>Foreword</b> .....	<b>3</b>
<b>Introduction</b> .....	<b>4</b>
<b>1 Scope</b> .....	<b>4</b>
<b>2 Normative references</b> .....	<b>4</b>
<b>3 Definitions</b> .....	<b>5</b>
<b>4 Dimensions and ratings</b> .....	<b>5</b>
<b>5 Requirements</b> .....	<b>9</b>
5.1 General requirements .....	9
5.2 Devices for hanging cargo .....	9
5.3 Strength of refrigeration or heating unit attachment.....	10
<b>6 Mandatory features</b> .....	<b>12</b>
6.1 Bottom fittings.....	12
6.2 Handling devices .....	12
6.2.1 Grappler arm lifting areas .....	12
6.2.2 Handling by means of slings.....	13
6.3 Load transfer areas.....	13
<b>7 Refrigerating or heating equipment</b> .....	<b>13</b>
<b>8 Electrical equipment</b> .....	<b>13</b>
<b>9 Optional devices</b> .....	<b>14</b>
9.1 Securing devices .....	14
9.2 Intermediate support.....	15
<b>10 Marking</b> .....	<b>15</b>

## Foreword

This European Standard has been prepared by Technical Committee CEN/TC 119 "Swap bodies for combined goods transport", the secretariat of which is held by DIN.

This European Standard shall be given the status of a national standard, either by publication of an identical text or by endorsement, at the latest by October 1999, and conflicting national standards shall be withdrawn at the latest by October 1999.

According to the CEN/CENELEC Internal Regulations, the national standards organizations of the following countries are bound to implement this European Standard: Austria, Belgium, Czech Republic, Denmark, Finland, France, Germany, Greece, Iceland, Ireland, Italy, Luxembourg, Netherlands, Norway, Portugal, Spain, Sweden, Switzerland and the United Kingdom.

The purpose of this standard is to combine the national standards into one single European standard to ensure for the future a free, unimpeded circulation of swap bodies in Europe within road/rail combined transport.

## Introduction

Thermal swap bodies are transportation equipment for transporting perishable goods.

## 1 Scope

This European standard specifies the dimensions and basic requirements for thermal swap bodies of class A.

These swap bodies are suitable for international exchange and for conveyance by road and rail including interchange between these forms of transport.

NOTE: "Class A" means that all swap bodies having this designation are equipped with bottom fittings positioned according to the specification for 1A (40') ISO Containers (see ISO 668:1995).

## 2 Normative references

This European Standard incorporates by dated or undated reference, provisions from other publications. These normative references are cited at the appropriate places in the text and the publications are listed hereafter. For dated references, subsequent amendments to or revisions of any of these publications apply to this European Standard only when incorporated in it by amendment or revision. For undated references the latest edition of the publication referred to applies.

EN 283	1991	Swap bodies - Testing
EN 452	1995	Swap bodies - Swap bodies of class A - Dimensions and general requirements
EN ISO 6346	1995	Freight containers - Coding, identification and marking (ISO 6346:1995)
ISO 668	1995	Series 1 freight containers - Classification, dimensions and ratings
ISO 1161	1984	Series 1 freight containers - Corner fittings - Specification
ISO 1496-2	1988	Series 1 freight containers - Specification and testing - Part 2 : Thermal containers
IEC 309-2	1989	Plugs, socket-outlets and couplers for industrial purposes - Part 2 : Dimensional interchangeability requirements for pin and contact-tube accessories

IEC 529	1991	Degrees of protection provided by enclosures
UIC 554-1 <sup>1)</sup>	1979	Supply of electrical equipment of railway vehicles from local mains supply or from an auxiliary generator 220 V or 380 V, 50 Hz - Safety requirements
UIC 592-4 <sup>1)</sup>	1985	Swap bodies which can be handled by grabs - Technical conditions
UIC 596-6 <sup>1)</sup>	1997	Traffic of road vehicles on wagons - Technical organisation - Conditions for coding load units in combined transport and combined transport lines

### 3 Definitions

For the purpose of this European standard, the definition after prEN 12406:1998 applies.

### 4 Dimensions and ratings

The external dimensions, tolerances and rating (*R*) of thermal swap bodies of class A are those specified in figure 1 and in table 1. No part of the swap body shall project beyond these specified overall external dimensions. The profile of swap bodies shall comply with figure 2.

---

<sup>1)</sup> To be obtained: UIC: 16, rue Jean Rey, F-75015 Paris

Dimensions in millimetres

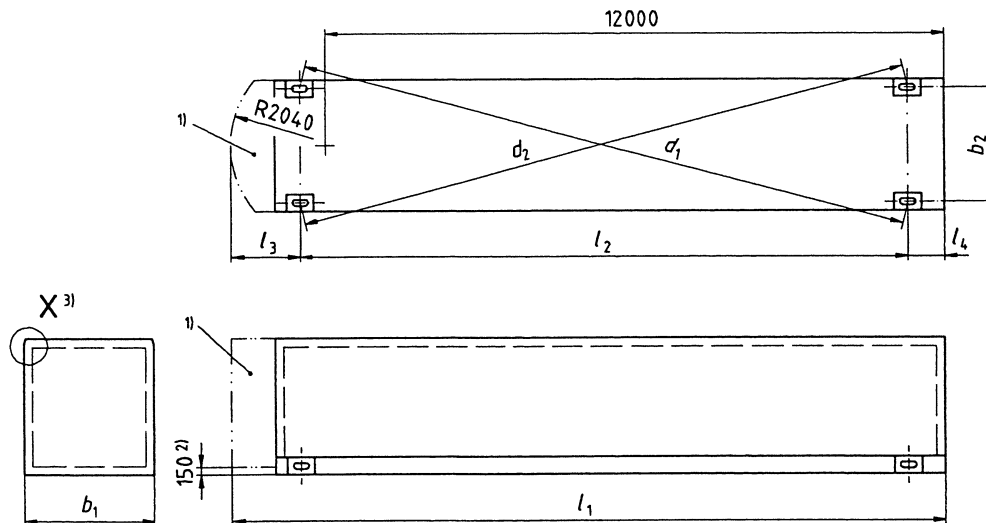

NOTE 1: Space to be reserved for the refrigerating or heating unit and the reservoir.

NOTE 2: Space to be reserved for the protection of the reservoir (see 9.1).

NOTE 3: For swap body widths from 2 530 mm to 2 600 mm (see figure 2).

**Figure 1 : Main dimensions**