

SVENSK STANDARD

SS-ISO 12164-4:2015

Fastställt/Approved: 2015-01-15
Publicerad/Published: 2015-01-16
Utgåva/Edition: 2
Språk/Language: engelska/English
ICS: 25.060.20

Verktygskopplingar – Konisk verktygskoppling med flänskontakt –

**Del 4: Mått för hållare för stationära verktyg
(ISO 12164-4:2014, IDT)**

**Hollow taper interface with flange contact surface –
Part 4: Dimensions of receivers for stationary tools
(ISO 12164-4:2014, IDT)**

This preview is downloaded from www.sis.se. Buy the entire standard via <https://www.sis.se/std-105133>

Standarder får världen att fungera

SIS (Swedish Standards Institute) är en fristående ideell förening med medlemmar från både privat och offentlig sektor. Vi är en del av det europeiska och globala nätverk som utarbetar internationella standarder. Standarder är dokumenterad kunskap utvecklad av framstående aktörer inom industri, näringsliv och samhälle och befrämjar handel över gränser, bidrar till att processer och produkter blir säkrare samt effektiviserar din verksamhet.

Delta och påverka

Som medlem i SIS har du möjlighet att påverka framtida standarder inom ditt område på nationell, europeisk och global nivå. Du får samtidigt tillgång till tidig information om utvecklingen inom din bransch.

Ta del av det färdiga arbetet

Vi erbjuder våra kunder allt som rör standarder och deras tillämpning. Hos oss kan du köpa alla publikationer du behöver – allt från enskilda standarder, tekniska rapporter och standardpaket till handböcker och onlinetjänster. Genom vår webbtjänst e-nav får du tillgång till ett lättnavigerat bibliotek där alla standarder som är aktuella för ditt företag finns tillgängliga. Standarder och handböcker är källor till kunskap. Vi säljer dem.

Utveckla din kompetens och lyckas bättre i ditt arbete

Hos SIS kan du gå öppna eller företagsinterna utbildningar kring innehåll och tillämpning av standarder. Genom vår närhet till den internationella utvecklingen och ISO får du rätt kunskap i rätt tid, direkt från källan. Med vår kunskap om standarders möjligheter hjälper vi våra kunder att skapa verklig nytta och lönsamhet i sina verksamheter.

Vill du veta mer om SIS eller hur standarder kan effektivisera din verksamhet är du välkommen in på www.sis.se eller ta kontakt med oss på tel 08-555 523 00.



Standards make the world go round

SIS (Swedish Standards Institute) is an independent non-profit organisation with members from both the private and public sectors. We are part of the European and global network that draws up international standards. Standards consist of documented knowledge developed by prominent actors within the industry, business world and society. They promote cross-border trade, they help to make processes and products safer and they streamline your organisation.

Take part and have influence

As a member of SIS you will have the possibility to participate in standardization activities on national, European and global level. The membership in SIS will give you the opportunity to influence future standards and gain access to early stage information about developments within your field.

Get to know the finished work

We offer our customers everything in connection with standards and their application. You can purchase all the publications you need from us - everything from individual standards, technical reports and standard packages through to manuals and online services. Our web service e-nav gives you access to an easy-to-navigate library where all standards that are relevant to your company are available. Standards and manuals are sources of knowledge. We sell them.

Increase understanding and improve perception

With SIS you can undergo either shared or in-house training in the content and application of standards. Thanks to our proximity to international development and ISO you receive the right knowledge at the right time, direct from the source. With our knowledge about the potential of standards, we assist our customers in creating tangible benefit and profitability in their organisations.

If you want to know more about SIS, or how standards can streamline your organisation, please visit www.sis.se or contact us on phone +46 (0)8-555 523 00



Den internationella standarden ISO 12164-4:2014 gäller som svensk standard. Detta dokument innehåller den officiella engelska versionen av ISO 12164-4:2014.

Denna standard ersätter SS-ISO 12164-4:2008, utgåva 1.

The International Standard ISO 12164-4:2014 has the status of a Swedish Standard. This document contains the official version of ISO 12164-4:2014.

This standard supersedes the Swedish Standard SS-ISO 12164-4:2008, edition 1.

© Copyright/Upphovsrätten till denna produkt tillhör SIS, Swedish Standards Institute, Stockholm, Sverige. Användningen av denna produkt regleras av slutanvändarlicensen som återfinns i denna produkt, se standardens sista sidor.

© Copyright SIS, Swedish Standards Institute, Stockholm, Sweden. All rights reserved. The use of this product is governed by the end-user licence for this product. You will find the licence in the end of this document.

Upplysningar om sakinnehållet i standarden lämnas av SIS, Swedish Standards Institute, telefon 08-555 520 00. Standarder kan beställas hos SIS Förlag AB som även lämnar allmänna upplysningar om svensk och utländsk standard.

Information about the content of the standard is available from the Swedish Standards Institute (SIS), telephone +46 8 555 520 00. Standards may be ordered from SIS Förlag AB, who can also provide general information about Swedish and foreign standards.

Denna standard är framtagen av kommittén för Skärande verktyg, SIS/TK 273.

Har du synpunkter på innehållet i den här standarden, vill du delta i ett kommande revideringsarbete eller vara med och ta fram andra standarder inom området? Gå in på www.sis.se - där hittar du mer information.

Contents

Page

Foreword	iv
1 Scope	1
2 Normative references	1
3 Dimensions	1
3.1 General.....	1
3.2 Receiver for hollow taper shank, type T.....	1
4 Design — Hole for manual clamping	3
5 Designation	3
Annex A (informative) Recommendations for use and application	5
Bibliography	6

Foreword

ISO (the International Organization for Standardization) is a worldwide federation of national standards bodies (ISO member bodies). The work of preparing International Standards is normally carried out through ISO technical committees. Each member body interested in a subject for which a technical committee has been established has the right to be represented on that committee. International organizations, governmental and non-governmental, in liaison with ISO, also take part in the work. ISO collaborates closely with the International Electrotechnical Commission (IEC) on all matters of electrotechnical standardization.

The procedures used to develop this document and those intended for its further maintenance are described in the ISO/IEC Directives, Part 1. In particular the different approval criteria needed for the different types of ISO documents should be noted. This document was drafted in accordance with the editorial rules of the ISO/IEC Directives, Part 2 (see www.iso.org/directives).

Attention is drawn to the possibility that some of the elements of this document may be the subject of patent rights. ISO shall not be held responsible for identifying any or all such patent rights. Details of any patent rights identified during the development of the document will be in the Introduction and/or on the ISO list of patent declarations received (see www.iso.org/patents).

Any trade name used in this document is information given for the convenience of users and does not constitute an endorsement.

For an explanation on the meaning of ISO specific terms and expressions related to conformity assessment, as well as information about ISO's adherence to the WTO principles in the Technical Barriers to Trade (TBT) see the following URL: Foreword - Supplementary information

The committee responsible for this document is ISO/TC 29, *Small tools*.

This second edition cancels and replaces the first edition (ISO 12164-4:2008), [Figure 1](#) of which has been technically revised.

ISO 12164 consists of the following parts, under the general title *Hollow taper interface with flange contact surface*:

- *Part 1: Shanks — Dimensions*
- *Part 2: Receivers — Dimensions*
- *Part 3: Dimensions of shanks for stationary tools*
- *Part 4: Dimensions of receivers for stationary tools*

Hollow taper interface with flange contact surface —

Part 4: Dimensions of receivers for stationary tools

1 Scope

This part of ISO 12164 specifies dimensions for receivers with taper and flange contact surfaces for hollow taper shanks in accordance with ISO 12164-3 to be applied to machine tools (e.g. turning machines, turning-mill machines). A range of sizes is specified.

This part of ISO 12164 specifies the receiver of type T. It is for automatic tool exchange and manual clamping, which is achieved via holes in both the receiver and the tool shank.

The torque is transmitted via the tail end of the shank through keys as well as friction.

2 Normative references

The following documents, in whole or in part, are normatively referenced in this document and are indispensable for its application. For dated references, only the edition cited applies. For undated references, the latest edition of the referenced document (including any amendments) applies.

ISO 1101, *Geometrical product specifications (GPS) — Geometrical tolerancing — Tolerances of form, orientation, location and run-out*

ISO 2768-1, *General tolerances — Part 1: Tolerances for linear and angular dimensions without individual tolerance indications*

ISO 3040, *Geometrical product specifications (GPS) — Dimensioning and tolerancing — Cones*

3 Dimensions

3.1 General

Dimensions of receivers for hollow taper shanks with flange contact surface for stationary tools, type T, are specified in [Figure 1](#), [Table 1](#), and [Annex A](#). Details not specified in [Figures 1](#) shall be chosen expediently. Tolerancing of form, orientation, location, and run-out is in accordance with ISO 1101. Dimensioning and tolerancing of cones are in accordance with ISO 3040. Tolerances not specified shall be of tolerance class «m» in accordance with ISO 2768-1.

3.2 Receiver for hollow taper shank, type T

The dimensions of receiver for hollow taper shanks, type T, shall be in conformance with [Figure 1](#) and [Table 1](#).

Dimensions in millimetres
 Surface roughness values in micrometres

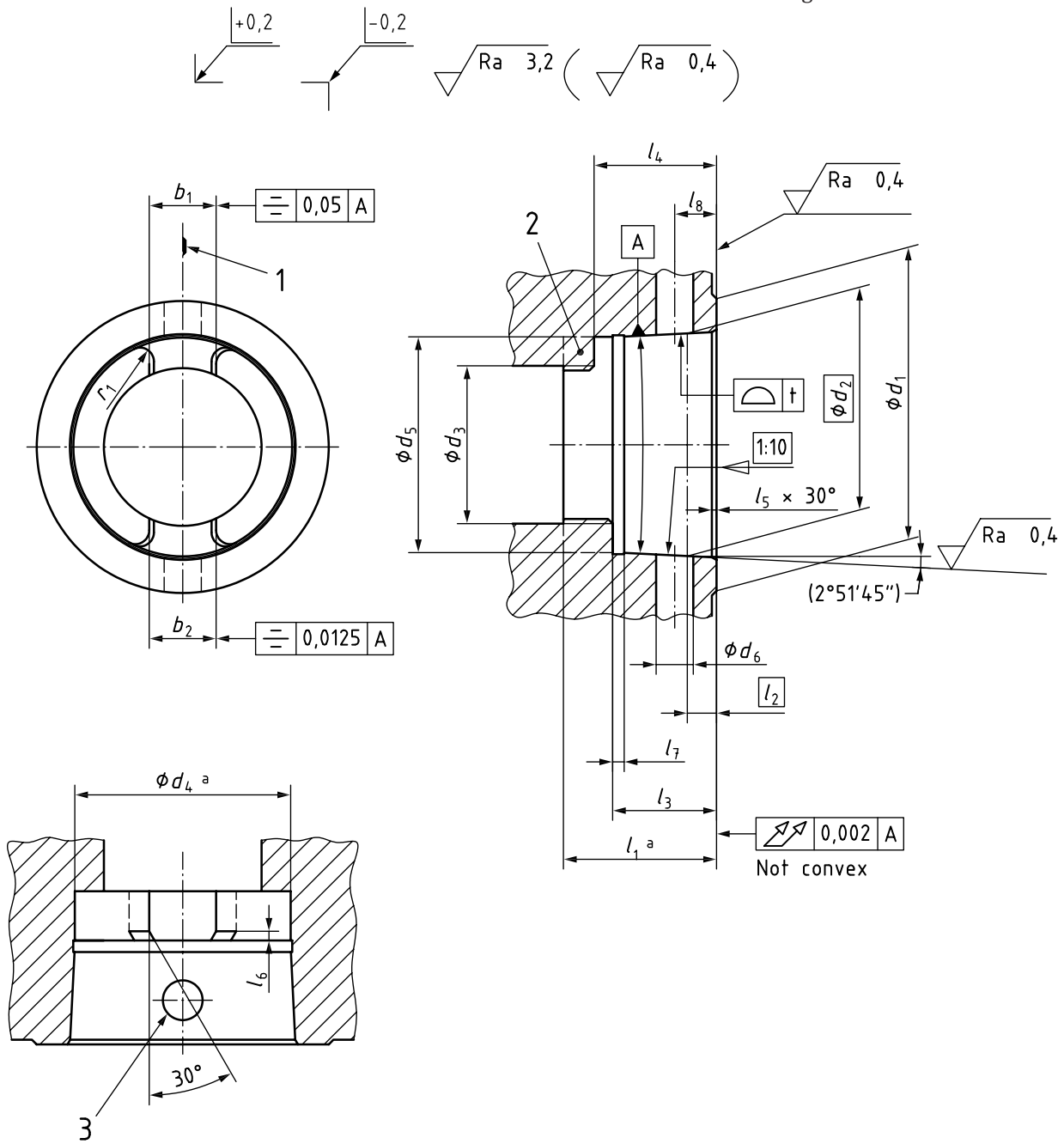

Key

- 1 cutting edge^b
- 2 tenon^c
- 3 hole for manual clamping^d
- a When tenons are inserted, the taper hole may be conical over the total length l_1 .
- b Position of the cutting edge for right-hand tools with single cutting edged.
- c Tenon alternative integrated or inserted.
- d Inside edge min. 0,5 mm \times 45° chamfer.

Figure 1 — Dimensions of receivers